



Index

4	What is due2?
7	Advantages
8	References
10	User's Guide
14	Installation Systems
24	Wood Effect
38	Stone Effect
74	Coping
75	Cleaning and Maintenance
76	Technical Characteristics
78	Terms and conditions of sale

Alphabetical Index

- 26 Arbor 
- 40 Chamonix 
- 54 Gotham 
- 62 La Scala 
- 32 Monteverde 
- 66 Travstone 
- 48 West 57th 

Index by Effect





Wood Effect

- 26 Arbor 
- 32 Monteverde 



Stone Effect

- 40 Chamonix 
- 48 West 57th 
- 54 Gotham 
- 62 La Scala 
- 66 Travstone 

What is due 2?

due2 is the collection of porcelain pavers by Del Conca USA, it includes all the trims and accessories needed to meet design needs in outdoor settings, from pedestrian walkways to rooftops or swimming pools. It is manufactured to the highest quality standards and has outstanding technical performances, including high resistance to wear, to mechanical stress, to weather and is anti-slip. Stylish aesthetics and a wide range of sizes make it a perfect fit for contemporary hardscapes and architecture.

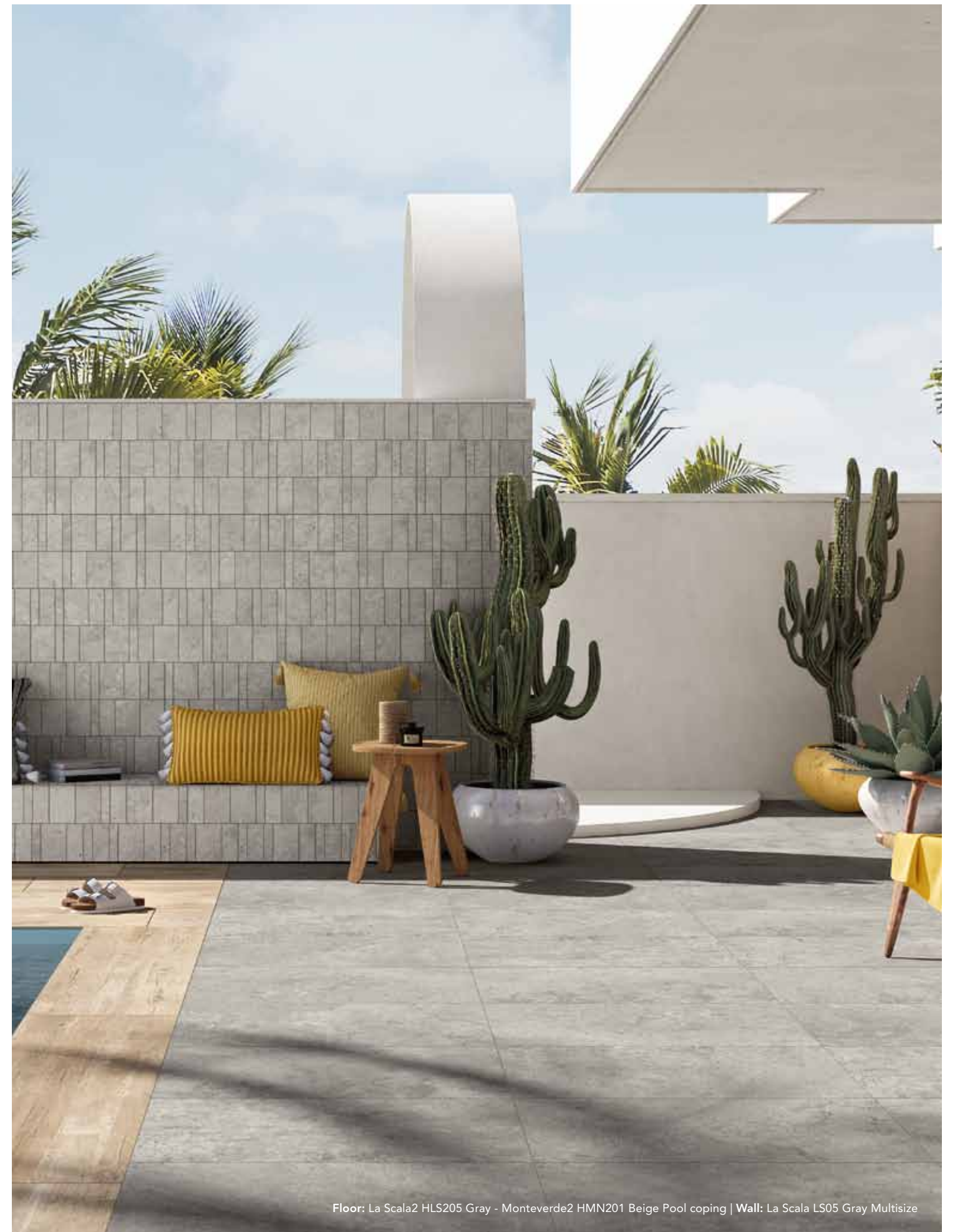

Floor: La Scala2 HLS205 Gray - Monteverde2 HMN201 Beige Pool coping | Wall: La Scala LS05 Gray Multisize



Floor: West 57th2 HWS210 Bianco

Advantages

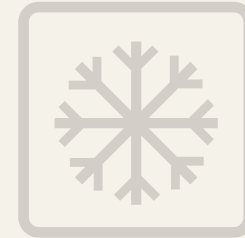

FROST RESISTANT



COLORS DO NOT FADE OVER TIME



RESISTANT TO SUDDEN TEMPERATURE CHANGES



RESISTANT TO ACID, CHEMICALS, SALT, ETC.



RESISTANT TO DAMAGE FROM MOLD AND MOSS



IMPERVIOUS



ANTI-SLIP



QUICK AND EASY TO INSTALL



EASY TO REMOVE



REUSABLE



READILY SERVICEABLE



INSTALLATION WITH ADHESIVE POSSIBLE



HIGHLY RESISTANT TO LOADS



WIDE RANGE OF FINISHES



ALLOWS WATER DRAINAGE

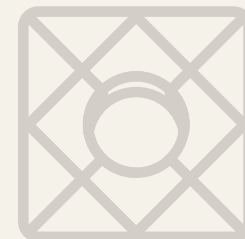

SPECIAL MATCHING PIECES



EXTREMELY LONG-LASTING



EASY TO CLEAN

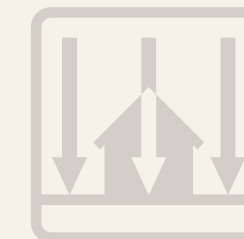

MATCHES INTERIOR FLOORING



SUITABLE FOR RAISED INSTALLATIONS

References



References

References

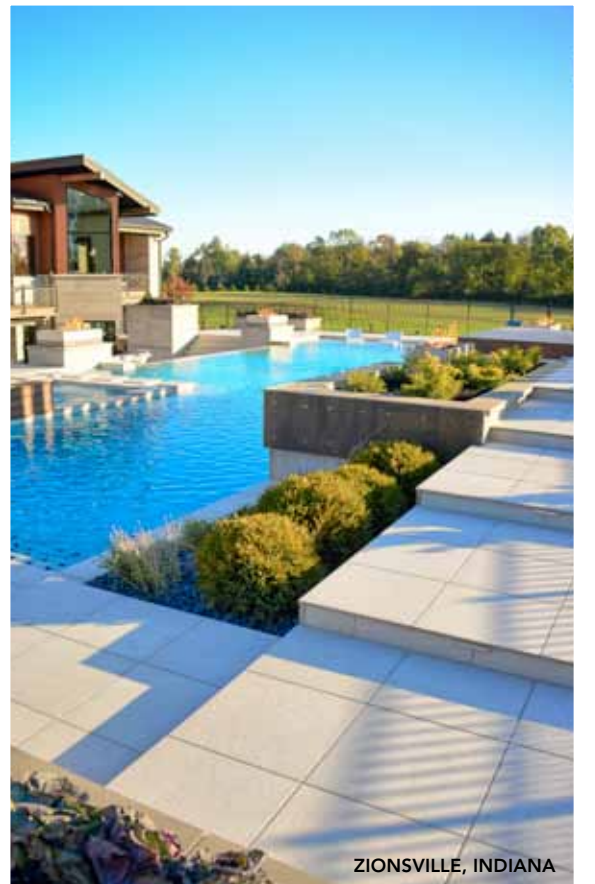

User's Guide

- 1 Name of the collection
- 2 Available sizes
- 3 Collection code
- 4 Colors summary
- 5 Effect
- 6 Technical characteristics
- 7 Graphics Number
- 8 Packaging specifications
- 9 Matching Indoor product

Chamonix ²
24"x24"

Colored Body Porcelain Pavers

ANSI A 137.1 compliant

- FLOOR
- MODERATE
- 0.75 in / 20 mm
- ASTM C 1525 RESISTANT
- ASTM C 1191 -6.1%
- ASTM C 480 CLASS A / ASTM C 1370 CLASS A
- ASTM C 440 -3000 BTU
- ANSI A 328.3 2017 (reissue 2019) ICCOM 10.60
- HEAVY USE

Chamonix
Available as 8.5 mm thick tile

COLLECTIONS BOOK 2021
Pag. 92

HCX²

HCX210 Bianco HCX201 Beige

HCX205 Gray HCX208 Dark Gray

Stone effect

Graphics number

Size	HCX10	HCX01	HCX05	HCX08
24"x24"	20	20	20	20

Packaging

Size	Pavers	Sq Ft.	Lbs.	Boxes	Sq Ft.	Lbs.
24"x24"	2	7.75	71.17	32	248.00	2277.30
12"x24" anti-slip	2	3.87	35.58	-	-	-
13"x24" anti-slip	1	2.53	29.45	-	-	-

User's Guide

1 Name of the collection

2 Available sizes

3 Item code

4 Item description

5 Size in inches and cm

6 Collection code

7 Effect

The image shows a product catalog page for the Chamonix collection. The page is divided into two columns, 46 and 47. The collection name 'Chamonix' is at the top left, with a '2' next to it. Below it, the size '24"x24"' is indicated. The page features four columns of products, each with a color swatch, a 3D perspective view, and a technical description. A red header bar on the right contains the collection code 'HCX²'. A vertical label 'Stone effect' is on the right side. Callouts 1-7 point to various elements: 1 points to the collection name, 2 to the size, 3 to the item code, 4 to the item description, 5 to the size in inches and cm, 6 to the collection code, and 7 to the stone effect label.

Item Code	Description	Size (inches)	Size (cm)	Thickness
59CX10	HCX210 Bianco	24"x24"	60x60 cm	
59CX01	HCX201 Beige	24"x24"	60x60 cm	
59CX05	HCX205 Gray	24"x24"	60x60 cm	
59CX08	HCX208 Dark Gray	24"x24"	60x60 cm	
58CX10C	HCX210 Bianco Pool Coping with full round edge	12"x24"	30x60 cm	
58CX01C	HCX201 Beige Pool Coping with full round edge	12"x24"	30x60 cm	
58CX05C	HCX205 Gray Pool Coping with full round edge	12"x24"	30x60 cm	
58CX08C	HCX208 Dark Gray Pool Coping with full round edge	12"x24"	30x60 cm	
78CX10G33	HCX310 Bianco Pool Coping	13"x24"	33x60 cm	1.18 in - 30 mm thick*
78CX01G33	HCX301 Beige Pool Coping	13"x24"	33x60 cm	1.18 in - 30 mm thick*
78CX05G33	HCX305 Gray Pool Coping	13"x24"	33x60 cm	1.18 in - 30 mm thick*
78CX08G33	HCX308 Dark Gray Pool Coping	13"x24"	33x60 cm	1.18 in - 30 mm thick*

Installation Systems



Installation Systems

Installation Systems

Lay-on Installation

Installation on grass

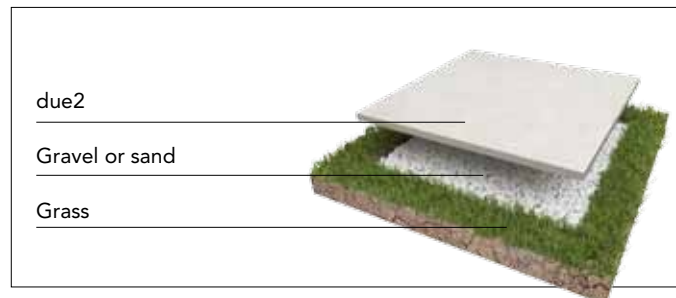

Installation as stepping stones on grass:

- remove the grass from the area underneath due2
- dig 2 inch deep in warm and dry climate, or deeper in cold or wet climates.
- compact the soil.
- fill the excavated area with gravel (size 1/6 - 1/3 inch) or sand and compact it.
- dry set due2

The stratigraphy shown is only an indication: we recommended referring to local regulations in order to achieve a correct installation.

Installation on gravel

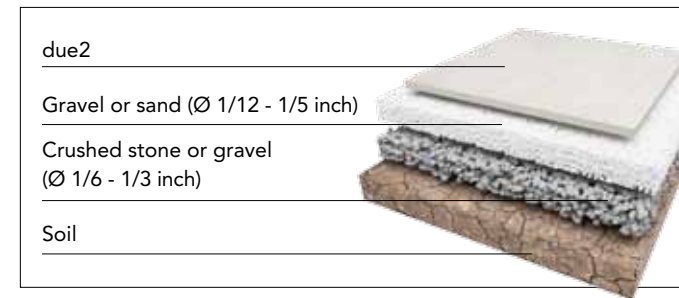

Recommended for larger areas, for installation with thin joints or joints without grass.

- Excavate the soil at least 4 inch deep in warm and dry climate, or deeper in cold or wet climates.
- Compact the soil at the bottom and ensure it is sloped ($\geq 2\%$) to avoid stagnation of water.
- Optional - place a layer of geotextile to keep the gravel from sinking into the soil.
- Place and compact a layer of crushed stone or gravel (size 1/6 - 1/3 inch).
- Optional - place a layer of geotextile to separate aggregates.
- Place and compact a layer of fine gravel or sand (size 1/12 - 1/5 inch) to ease the leveling of the surface.
- Ensure the surface is level using a straightedge. A slight slope ($\geq 1\%$) is recommended to ensure proper drainage of the floor.
- Dry set due2 leaving joints at least 1/8 inch wide. Tile spacers can be used to facilitate installation. Ensure the floor is level with a straightedge and use a rubber hammer to correct small differences in height.
- Fill the joints with very fine sand (size 0 - 1/8 inch) or polymeric sand.

The stratigraphy shown is only an indication: we recommended referring to local regulations in order to achieve a correct installation.



Floor: West 57th2 HWS210 Bianco



Floor: Arbor2 HAO205 Gray

Lay-on Installation

Installation on sand



Installation on sand can be performed directly:

- level and compact the sand
- dry set due2

The stratigraphy shown is only an indication: we recommend referring to local regulations in order to achieve a correct installation.

Installation on concrete slab

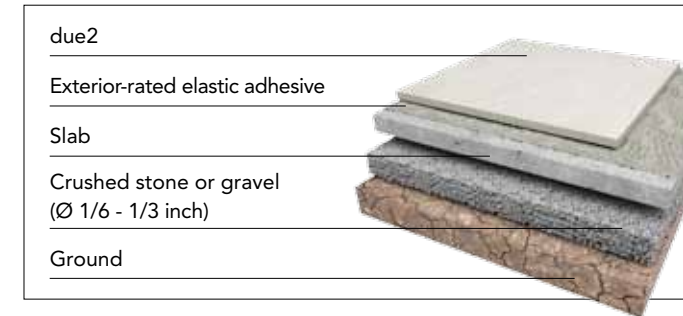

Installation with thin set on concrete slab recommended for areas open to vehicular traffic or subject to very high stress: leave joints at least 1/8 inch wide and respect expansion joints.

- To install on concrete slab on ground:
- complete the digging and compact the soil
 - Place a layer of crushed stone or gravel
 - Place the slab including optional steel mesh
 - Install due2 with exterior-rated elastic adhesive

The stratigraphy shown is only an indication: we recommend referring to local regulations in order to achieve a correct installation.



Floor: Monteverde2 HMN205 Gray



Floor: Travstone2 HTS205 Gray

Raised Installation

Raised installation



The stratigraphy shown is only an indication: we recommended referring to local regulations in order to achieve a correct installation.

due2 can also be used to create perfectly flat, practical raised floors for use on balconies and roof terraces, allowing rainwater to flow underneath the paving and into the waterproofing system, where an inspectable cavity is created that can be used for cable routing and to house utilities systems, also helping to improve the building's insulation. After the slab and its sloping screed are complete, install the waterproofing membrane. Position the pedestals according to the chosen sizes, if necessary use the slope correctors. During the installation, adjust each pedestal to achieve a flat floor.

How to cut it

To cut due2, it is necessary to use discs designed for Porcelain Pavers, available for both dry and wet cutting.

Adjustable pedestals with fixed head

Taller pedestals are available on request.

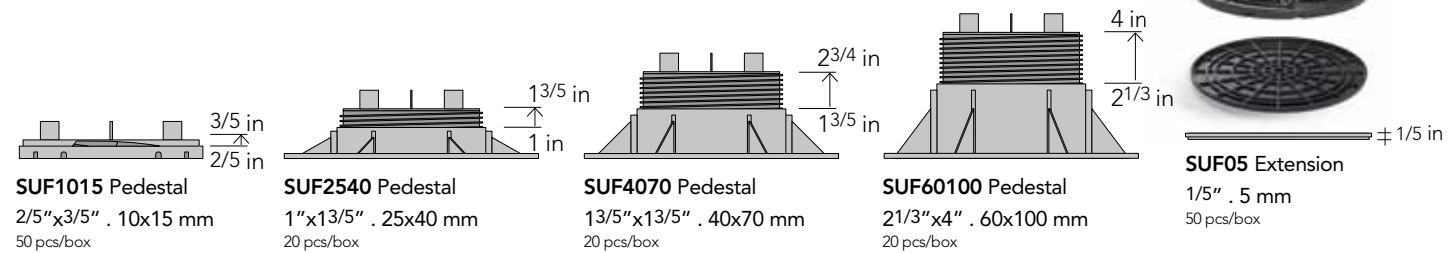

PEDESTALS LOAD BEARING DETAILS
Operating load = 2204 lbs. (1000 kg) each. Breaking load > 4409 lbs. (2000 kg) each.

Adjustable pedestals with self-levelling head

Taller pedestals are available on request.

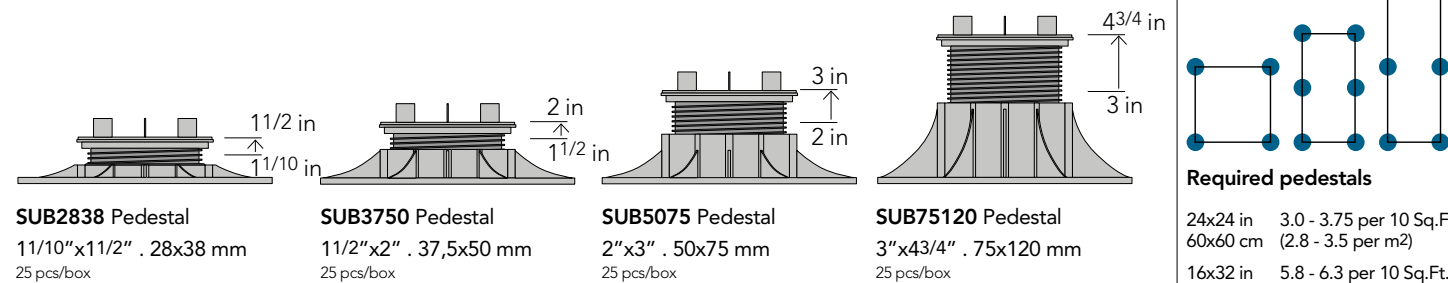

PEDESTALS LOAD BEARING DETAILS
Operating load = 1102 lbs. (500 kg) each. Breaking load > 2204 lbs. (1000 kg) each.



Pre-cut tabs for easy removal. Reinforced adjustment key. Bi-material head (PP + rubber) anti-noise and anti-slip.

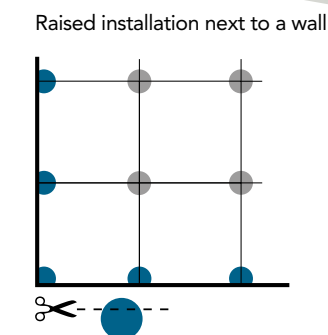
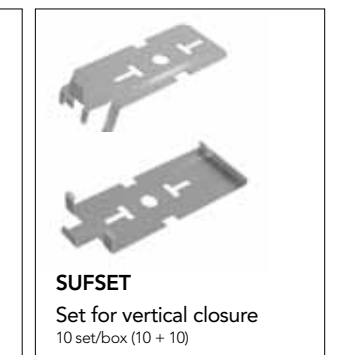
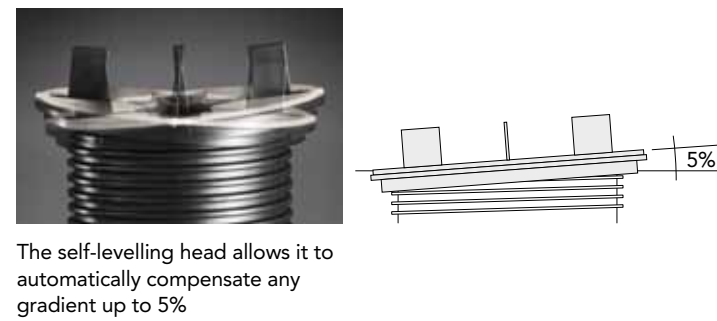

Raised installation with Slope regulators



For a proper water outflow we suggest to lay with 1% minimum slope

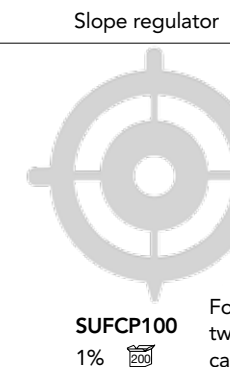
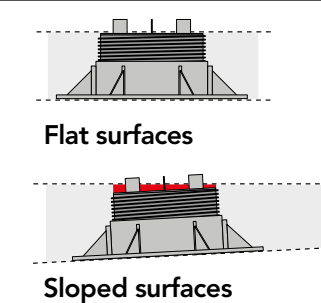

For slopes over 1%, two or more slope regulators can be piled up on each other.

Raised Installation

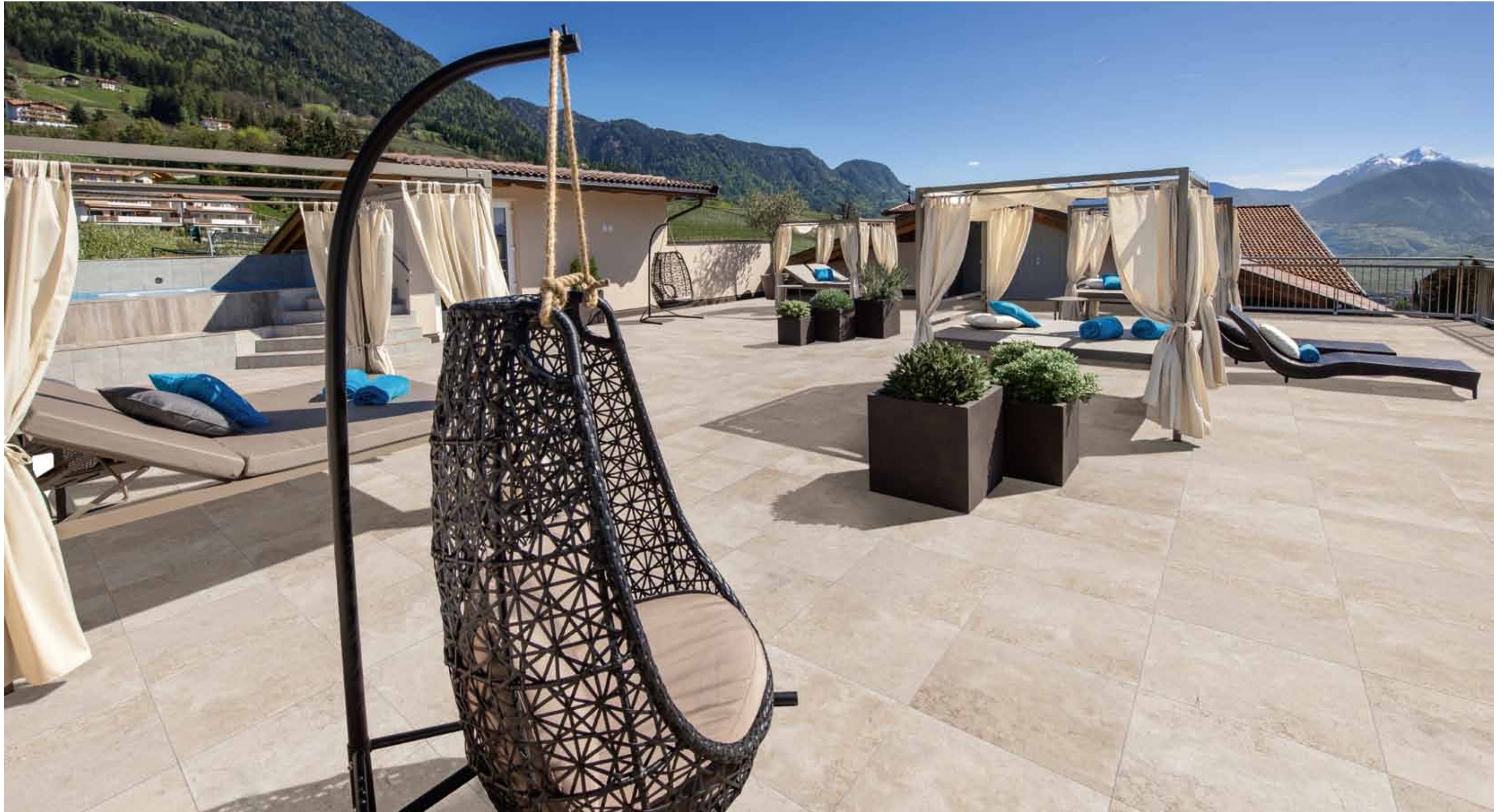

Wood Effect

Arbor **2** 26
Monteverde **2** 32

Arbor 2

16"x32"

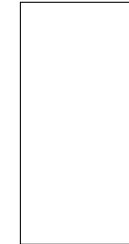

16"x32" . 40x80 cm

Colored Body Porcelain Pavers



HAO210 Bianco



HAO205 Gray



HAO203 Natural

ANSI A 137.1 compliant

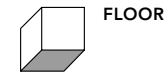

FLOOR



HIGH



0.79 in
20 mm



ASTM C 1026
RESISTANT



ASTM C 373
~0.1%



ASTM C 650: CLASS A
ASTM C 1378: CLASS A



ASTM C 648: ~3000 lbf.



ANSI A 326.3:2017 release 2019.
(DCOF): ≥0,60





HEAVY USE

Graphics number

Sizes	HAO210	HAO205	HAO203
16"x32"	32	32	32

Packaging

Sizes	Pieces					
		Sq.Ft.	Lbs.	Boxes	Sq.Ft.	Lbs.
16"x32"	2	6.89	64.12	39	268.71	2500.00
16"x32" pool coping	2	6.89	62.31	-	-	-

Arbor 2

16"x32"

HAO²

Wood Effect



Wood Effect



Floor: HAO210 Bianco

Arbor 2

16"x32"



SOAO10
 HAO210 Bianco
 16"x32" . 40x80 cm



SOAO05
 HAO205 Gray
 16"x32" . 40x80 cm



SOAO03
 HAO203 Natural
 16"x32" . 40x80 cm



SOAO10C
 HAO210 Bianco Pool Coping
 with full round edge
 16"x32" . 40x80 cm



SOAO05C
 HAO205 Gray Pool Coping
 with full round edge
 16"x32" . 40x80 cm



SOAO03C
 HAO203 Natural Pool Coping
 with full round edge
 16"x32" . 40x80 cm

Monteverde **2**

16"x48"

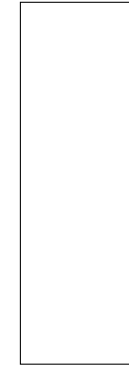

16"x48" . 40x120 cm

Colored Body Porcelain Pavers



HMN201 Beige



HMN205 Gray



HMN209 Noce

ANSI A 137.1 compliant

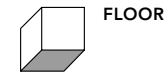

FLOOR



HIGH



0.79 in
20 mm



ASTM C 1026
RESISTANT



ASTM C 373
~0.1%



ASTM C 650: CLASS A
ASTM C 1378: CLASS A



ASTM C 648: ~3000 lbf.



ANSI A 326.3:2017 release 2019.
(DCOF): ≥0,60





HEAVY USE

Made in Italy

Graphics number

Sizes	HMN201	HMN205	HMN209
16"x48"	27	27	27

Packaging

Sizes	Pieces						
		Sq.Ft.	Lbs.	Boxes	Sq.Ft.	Lbs.	
16"x48"	1	5.17	51.80	54	279.18	2797.60	
16"x48" pool coping	1	5.17	49.82	-	-	-	

Monteverde 2

16"x48"

HMN²

Wood Effect

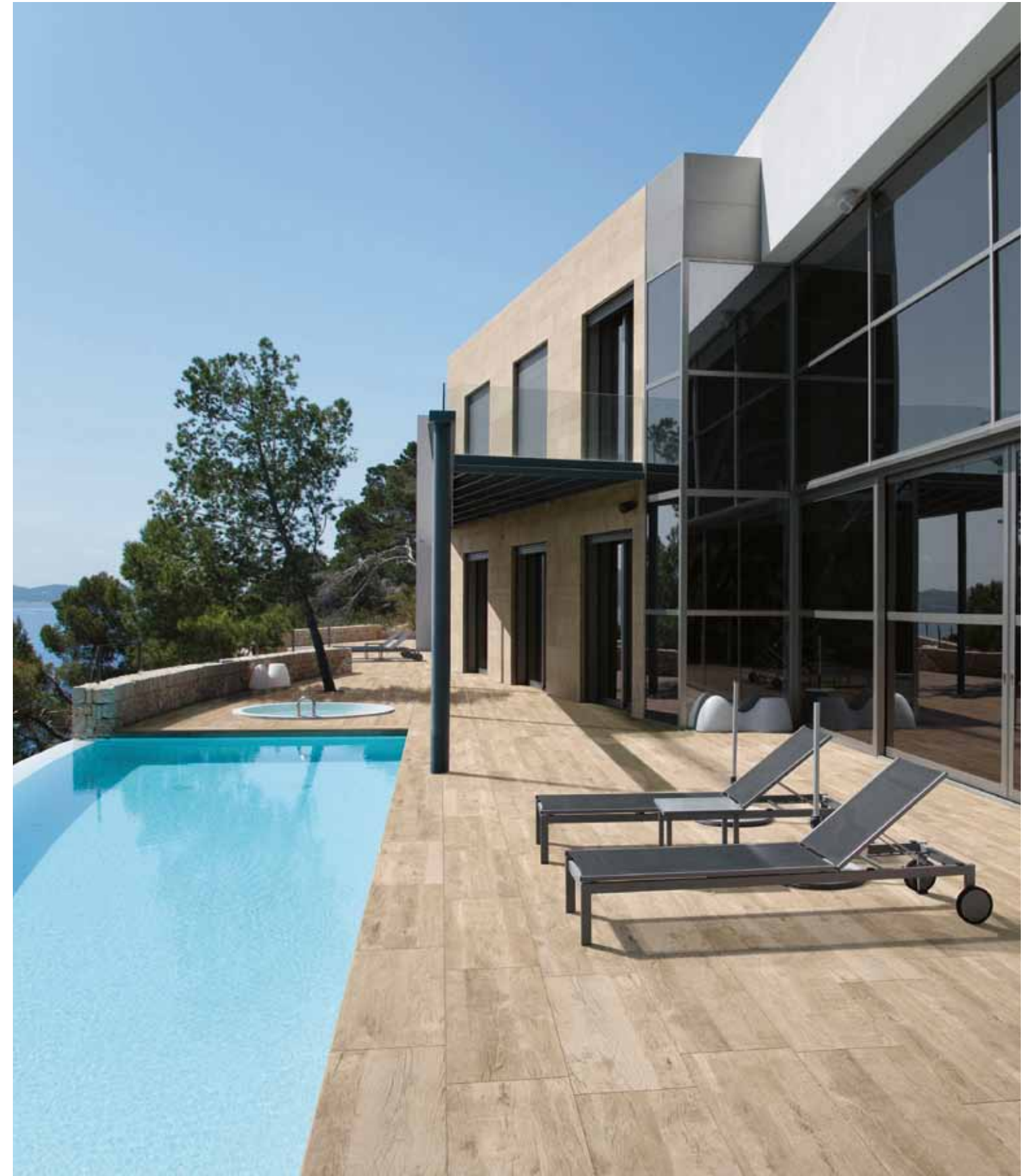

Wood Effect

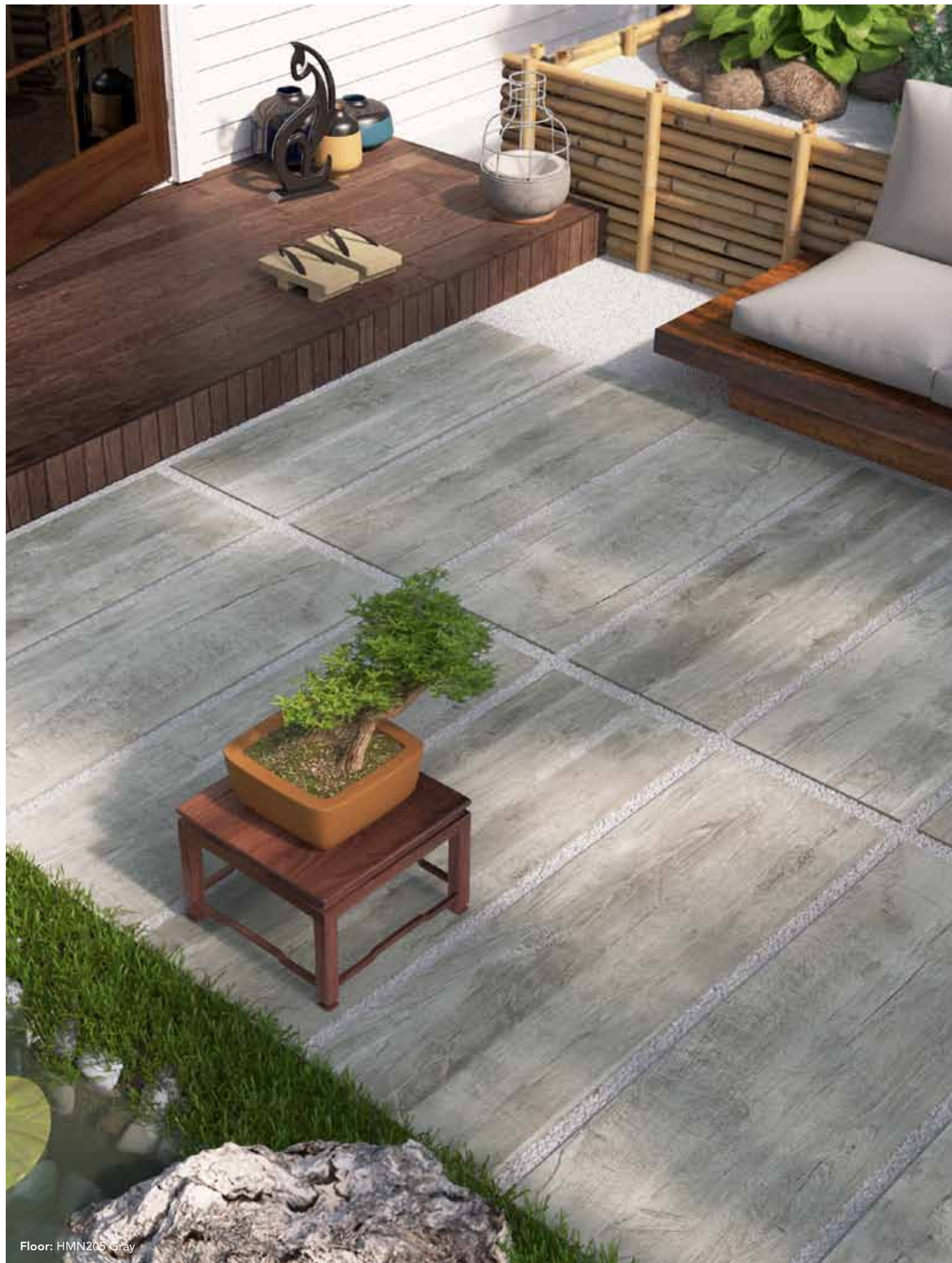

Floor: HMN205 Gray

Monteverde 2

16"x48"



SDMN01
HMN201 Beige
16"x48" . 40x120 cm



SDMN05
HMN205 Gray
16"x48" . 40x120 cm



SDMN09
HMN209 Noce
16"x48" . 40x120 cm



SDMN01C
HMN201 Beige Pool Coping
with full round edge
16"x48" . 40x120 cm



SDMN05C
HMN205 Gray Pool Coping
with full round edge
16"x48" . 40x120 cm



SDMN09C
HMN209 Noce Pool Coping
with full round edge
16"x48" . 40x120 cm

Stone Effect

Chamonix 2	40
West 57th 2	48
Gotham 2	54
La Scala 2	62
Travstone 2	66

Chamonix **2**

24"x24"

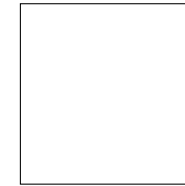

24"x24" . 60x60 cm

Colored Body Porcelain Pavers

ANSI A 137.1 compliant

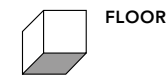

FLOOR



MODERATE



0.78 in
20 mm



ASTM C 1026
RESISTANT



ASTM C 373
~0.1%



ASTM C 650: CLASS A
ASTM C 1378: CLASS A



ASTM C 648: ~3000 lbf.



ANSI A 326.3:2017 release 2019.
(DCOF): ≥0,60



HEAVY USE

Chamonix

Available as 8.5 mm thick tile



COLLECTIONS BOOK 2021
Pag. 82



HCX210 Bianco



HCX201 Beige



HCX205 Gray



HCX208 Dark Gray

Graphics number

Sizes	HCX210	HCX201	HCX205	HCX208
24"x24"	20	20	20	20

Packaging

Sizes	Pieces	Sq.Ft.	Lbs.	Boxes	Sq.Ft.	Lbs.
24"x24"	2	7.75	71.17	32	248.00	2277.30
12"x24" pool coping	2	3.87	35.58	-	-	-
13"x24" pool coping*	1	2.13	29.65	-	-	-

Chamonix 2

24"x24"

HCX²

Stone Effect

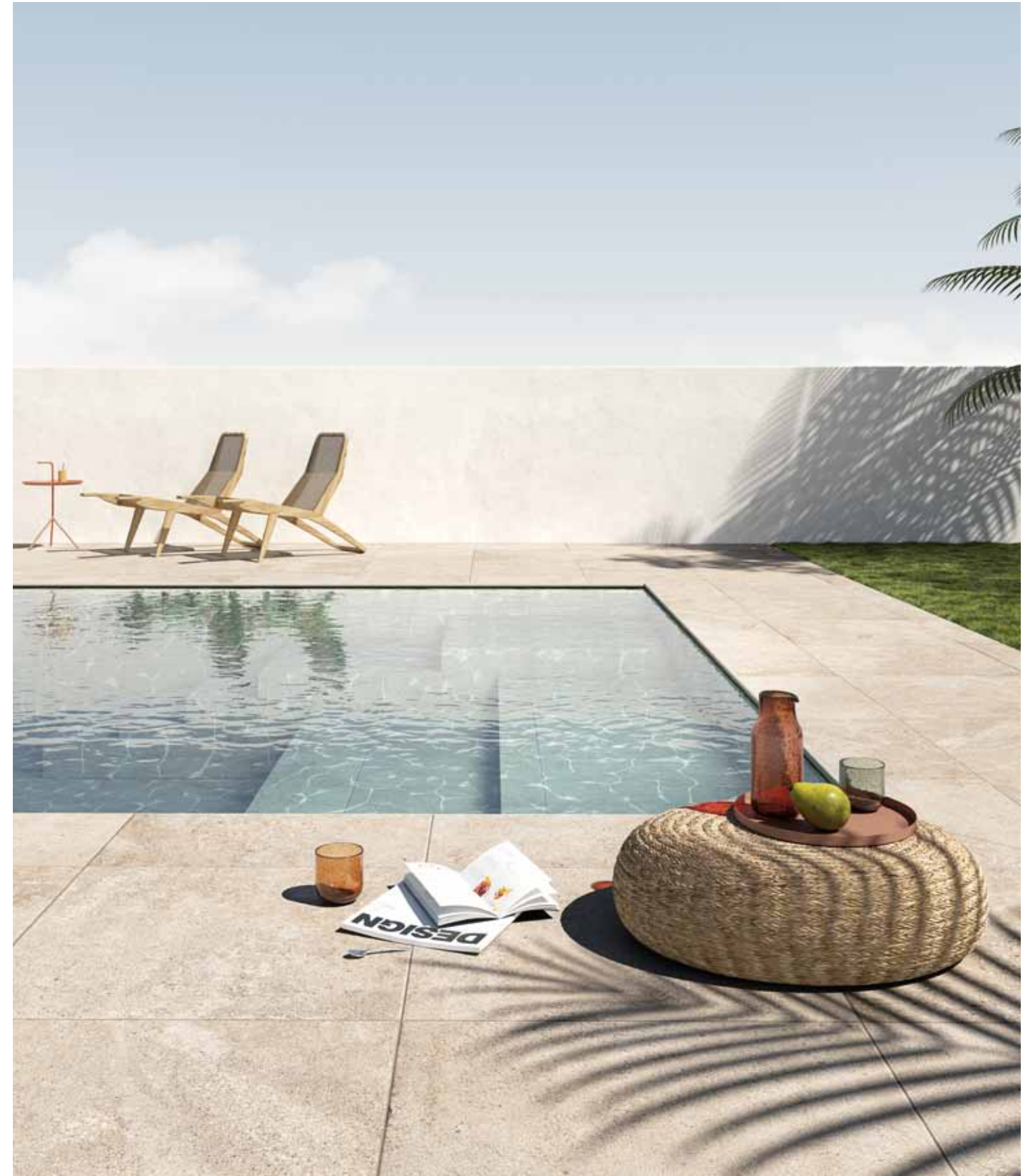
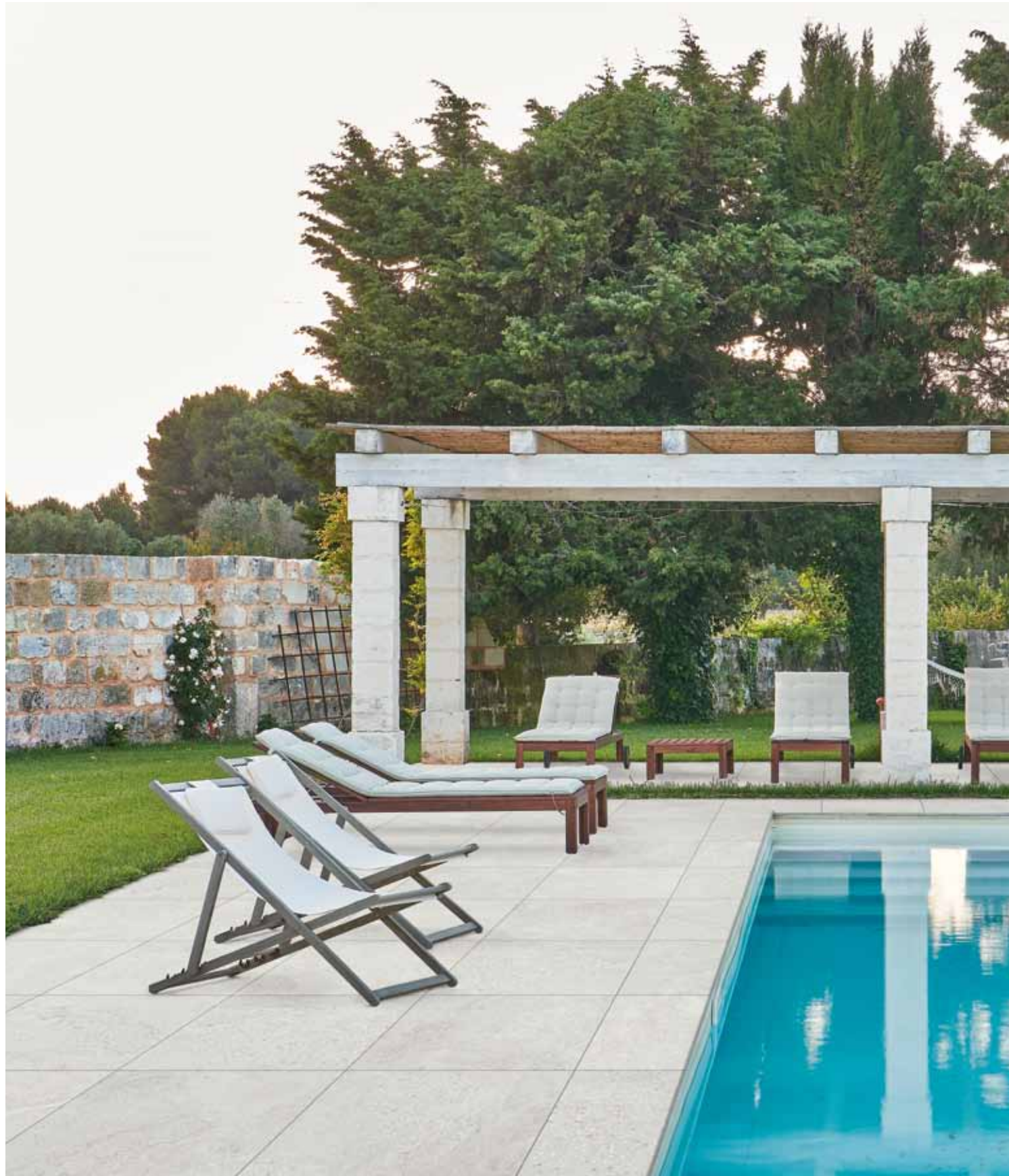

Stone Effect

Chamonix 2

24"x24"

HCX²

Stone Effect

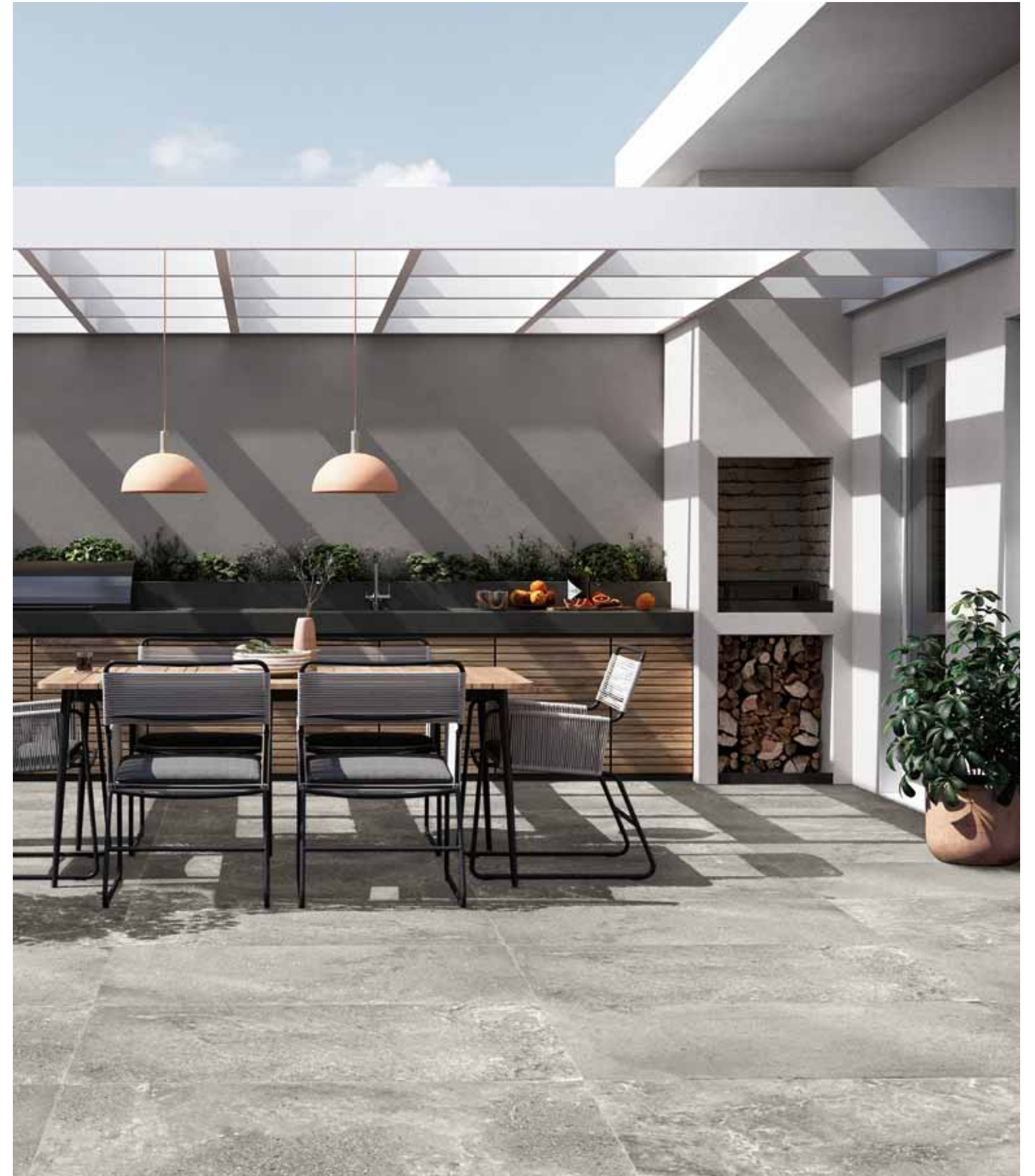

Stone Effect

Chamonix **2**

24"x24"



S9CX10
HCX210 Bianco
24"x24" . 60x60 cm



S9CX01
HCX201 Beige
24"x24" . 60x60 cm



S9CX05
HCX205 Gray
24"x24" . 60x60 cm



S9CX08
HCX208 Dark Gray
24"x24" . 60x60 cm



S8CX10C
HCX210 Bianco Pool Coping
with full round edge
12"x24" . 30x60 cm



S8CX01C
HCX201 Beige Pool Coping
with full round edge
12"x24" . 30x60 cm



S8CX05C
HCX205 Gray Pool Coping
with full round edge
12"x24" . 30x60 cm



S8CX08C
HCX208 Dark Gray Pool Coping
with full round edge
12"x24" . 30x60 cm



T8CX10G33
HCX310 Bianco Pool Coping
13"x24" . 33x60 cm
1.18 in - 30 mm thick*



T8CX01G33
HCX301 Beige Pool Coping
13"x24" . 33x60 cm
1.18 in - 30 mm thick*



T8CX05G33
HCX305 Gray Pool Coping
13"x24" . 33x60 cm
1.18 in - 30 mm thick*



T8CX08G33
HCX308 Dark Gray Pool Coping
13"x24" . 33x60 cm
1.18 in - 30 mm thick*

West 57th 2

24"x24"

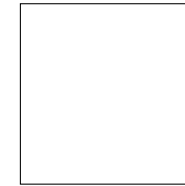

24"x24" . 60x60 cm

Colored Body Porcelain Pavers

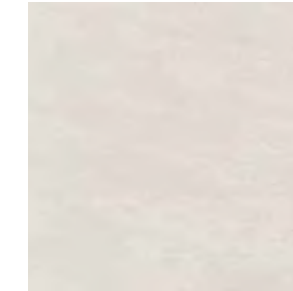

HWS210 Bianco



HWS201 Beige

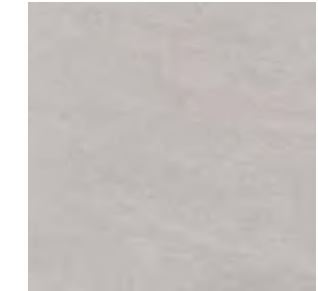

HWS205 Gray

ANSI A 137.1 compliant

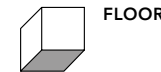

FLOOR



MODERATE



0.79 in
20 mm



ASTM C 1026
RESISTANT



ASTM C 373
~0.1%



ASTM C 650: CLASS A
ASTM C 1378: CLASS A



ASTM C 648: ~3000 lbf.



ANSI A 326.3:2017 release 2019.
(DCOF): ≥0,60



HEAVY USE

West 57th

Available as 8.5 mm thick tile



COLLECTIONS BOOK 2021
Pag. 92

Graphics number

Sizes	HWS210	HWS201	HWS205
24"x24"	14	14	14

Packaging

Sizes						
	Pieces	Sq.Ft.	Lbs.	Boxes	Sq.Ft.	Lbs.
24"x24"	2	7.75	71.17	32	248.00	2277.30
12"x24" pool coping	2	3.87	35.58	-	-	-

West 57th 2

24"x24"

HWS²



Stone Effect

Stone Effect

West 57th 2

24"x24"

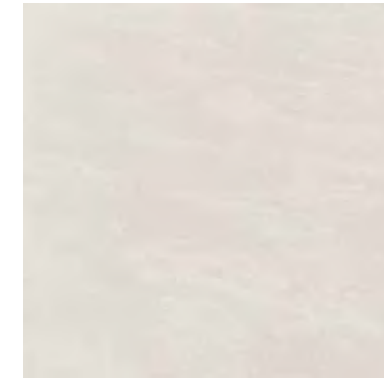

S9WS60U
HWS210 Bianco
24"x24" . 60x60 cm



S9WS51U
HWS201 Beige
24"x24" . 60x60 cm



S9WS55U
HWS205 Gray
24"x24" . 60x60 cm

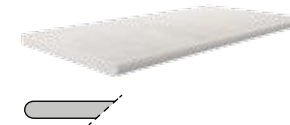

S8WS10C
HWS210 Bianco Pool Coping
with full round edge
12"x24" . 30x60 cm



S8WS01C
HWS201 Beige Pool Coping
with full round edge
12"x24" . 30x60 cm



S8WS05C
HWS205 Gray Pool Coping
with full round edge
12"x24" . 30x60 cm

Stone Effect



Floor: HWS201 Beige

Stone Effect

Gotham 2

24"x24"

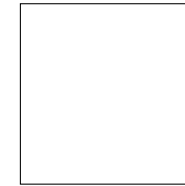

24"x24" . 60x60 cm

Colored Body Porcelain Pavers

ANSI A 137.1 compliant

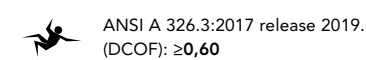
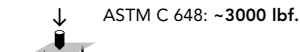
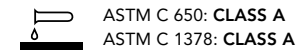
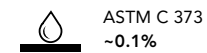
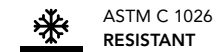
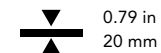
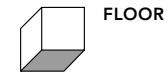

HGO210 Bianco



HGO205 Gray



HGO201 Beige



HGO208 Nero

Graphics number

Sizes	HGO210	HGO205	HGO201	HGO208
24"x24"	39	14	9	24

Packaging

Sizes	Pieces	Sq.Ft.	Lbs.	Boxes	Sq.Ft.	Lbs.
24"x24"	2	7.75	71.17	32	248.00	2277.30
12"x24" pool coping	2	3.87	35.58	-	-	-
13"x24" pool coping*	1	2.13	29.65	-	-	-

Gotham

Available as 8.5 mm thick tile



COLLECTIONS BOOK 2021
Pag. 110

Gotham **2**

24"x24"



Stone Effect

Stone Effect

Gotham 2

24"x24"



Stone Effect

Stone Effect

Gotham 2

24"x24"



S9GO60U
HGO210 Bianco
24"x24" . 60x60 cm



S9GO51U
HGO201 Beige
24"x24" . 60x60 cm



S9GO55U
HGO205 Gray
24"x24" . 60x60 cm



S9GO58U
HGO208 Nero
24"x24" . 60x60 cm



S8GO10C
HGO210 Bianco Pool Coping
with full round edge
12"x24" . 30x60 cm

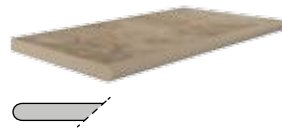

S8GO01C
HGO201 Beige Pool Coping
with full round edge
12"x24" . 30x60 cm



S8GO05C
HGO205 Gray Pool Coping
with full round edge
12"x24" . 30x60 cm

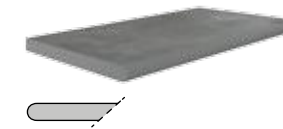

S8GO08C
HGO208 Nero Pool Coping
with full round edge
12"x24" . 30x60 cm



T8GO10G33
HGO310 Bianco Pool Coping
13"x24" . 33x60 cm
1.18 in - 30 mm thick*



T8GO01G33
HGO301 Beige Pool Coping
13"x24" . 33x60 cm
1.18 in - 30 mm thick*



T8GO05G33
HGO305 Gray Pool Coping
13"x24" . 33x60 cm
1.18 in - 30 mm thick*



T8GO08G33
HGO308 Nero Pool Coping
13"x24" . 33x60 cm
1.18 in - 30 mm thick*



La Scala 2

16"x32"



16"x32" . 40x80 cm

Colored Body Porcelain Pavers

ANSI A 137.1 compliant

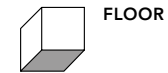

FLOOR



MODERATE



0.79 in
20 mm



ASTM C 1026
RESISTANT



ASTM C 373
~0.1%



ASTM C 650: CLASS A
ASTM C 1378: CLASS A



ASTM C 648: ~3000 lbf.



ANSI A 326.3:2017 release 2019.
(DCOF): ≥0,60



HEAVY USE

La Scala

Available as 8.5 mm thick tile



COLLECTIONS BOOK 2021
Pag. 128

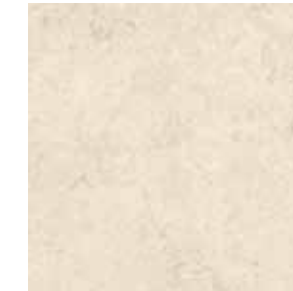

HLS201 Beige



HLS209 Noce



HLS205 Gray

Graphics number

Sizes	HLS201	HLS209	HLS205
16"x32"	24	33	18

Packaging

Sizes	Pieces						
		Sq.Ft.	Lbs.	Boxes	Sq.Ft.	Lbs.	
16"x32"	2	6.89	64.66	24	165.36	1552.00	
16"x32" pool coping	2	6.89	64.66	-	-	-	



Floor: La Scala2 HLS205 Gray - Monteverde2 HMN201 Beige Pool coping | Wall: La Scala LS05 Gray Multisize

La Scala 2

16"x32"

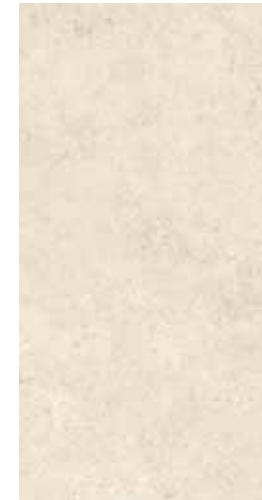

SOLS51U
HLS201 Beige
16"x32" . 40x80 cm



SOLS09
HLS209 Noce
16"x32" . 40x80 cm



SOLS55U
HLS205 Gray
16"x32" . 40x80 cm



SOLS01C
HLS201 Beige Pool Coping
with full round edge
16"x32" . 40x80 cm



SOLS09C
HLS209 Noce Pool Coping
with full round edge
16"x32" . 40x80 cm



SOLS05C
HLS205 Gray Pool Coping
with full round edge
16"x32" . 40x80 cm

Travstone 2

24"x24" 16"x32"

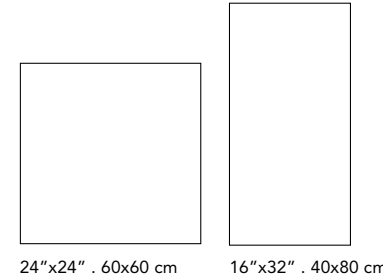

24"x24" . 60x60 cm 16"x32" . 40x80 cm

Colored Body Porcelain Pavers



HTS201 Beige



HTS209 Noce



HTS205 Gray

ANSI A 137.1 compliant

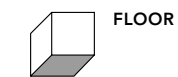

FLOOR



HIGH



0.79 in
20 mm



ASTM C 1026
RESISTANT

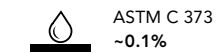

ASTM C 373
~0.1%

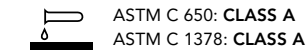

ASTM C 650: CLASS A
ASTM C 1378: CLASS A

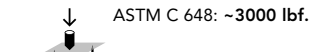

ASTM C 648: ~3000 lbf.

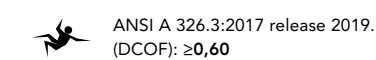

ANSI A 326.3:2017 release 2019.
(DCOF): ≥0,60





HEAVY USE

Graphics number

Sizes	HTS201	HTS209	HTS205
24"x24"	24	12	12
16"x32"	20		12

Packaging

Sizes	Pieces					
		Sq.Ft.	Lbs.	Boxes	Sq.Ft.	Lbs.
24"x24"	2	7.75	71.17	32	248.00	2277.30
16"x32"	2	6.89	64.66	24	165.36	1552.00
16"x32" pool coping	2	6.89	64.66	-	-	-
12"x24" pool coping	2	3.87	35.58	-	-	-
13"x24" pool coping*	1	2.13	29.65	-	-	-

Travstone 2

24"x24" 16"x32"

Stone Effect



Stone Effect

Travstone 2

24"x24" 16"x32"

Stone Effect

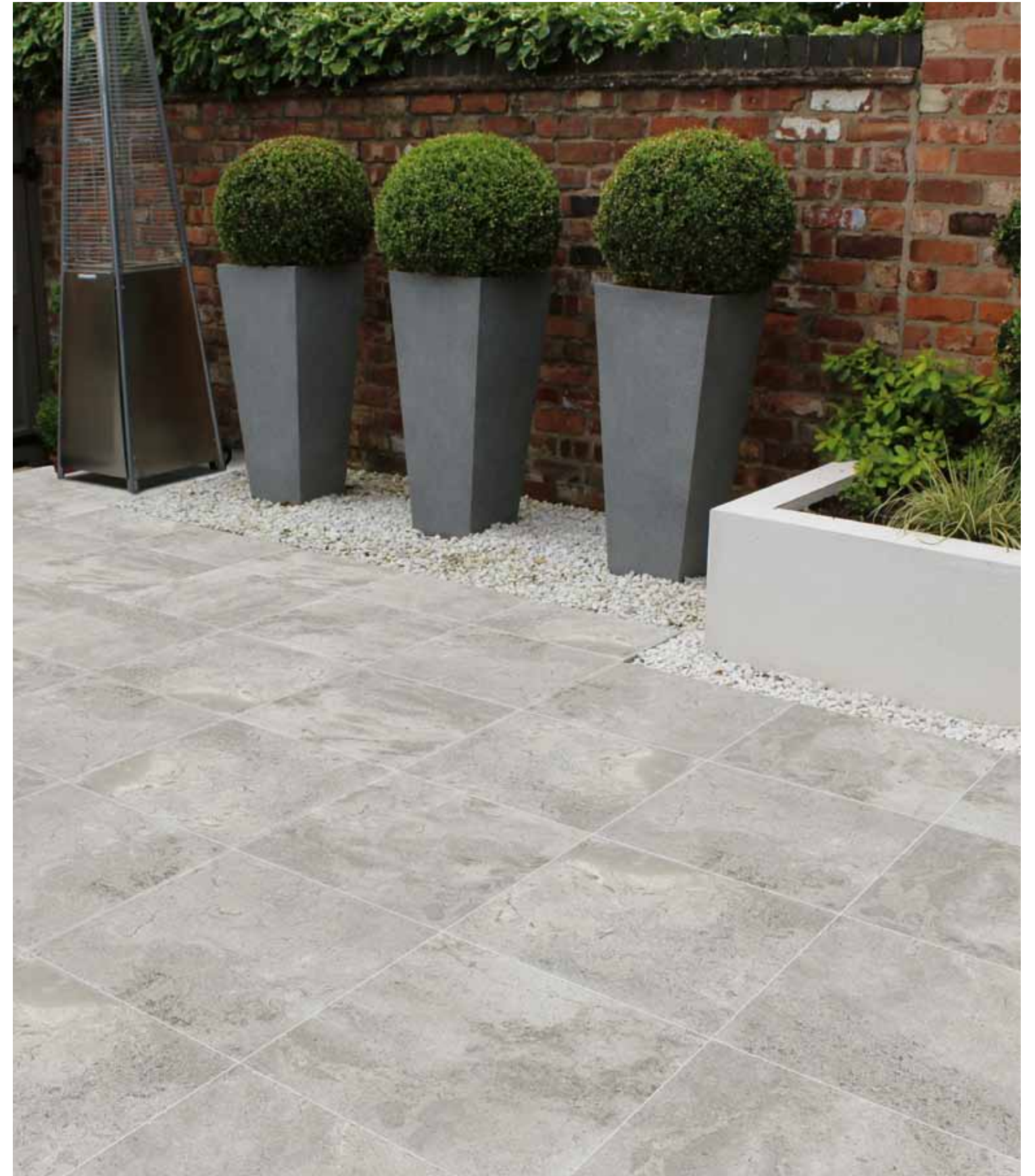
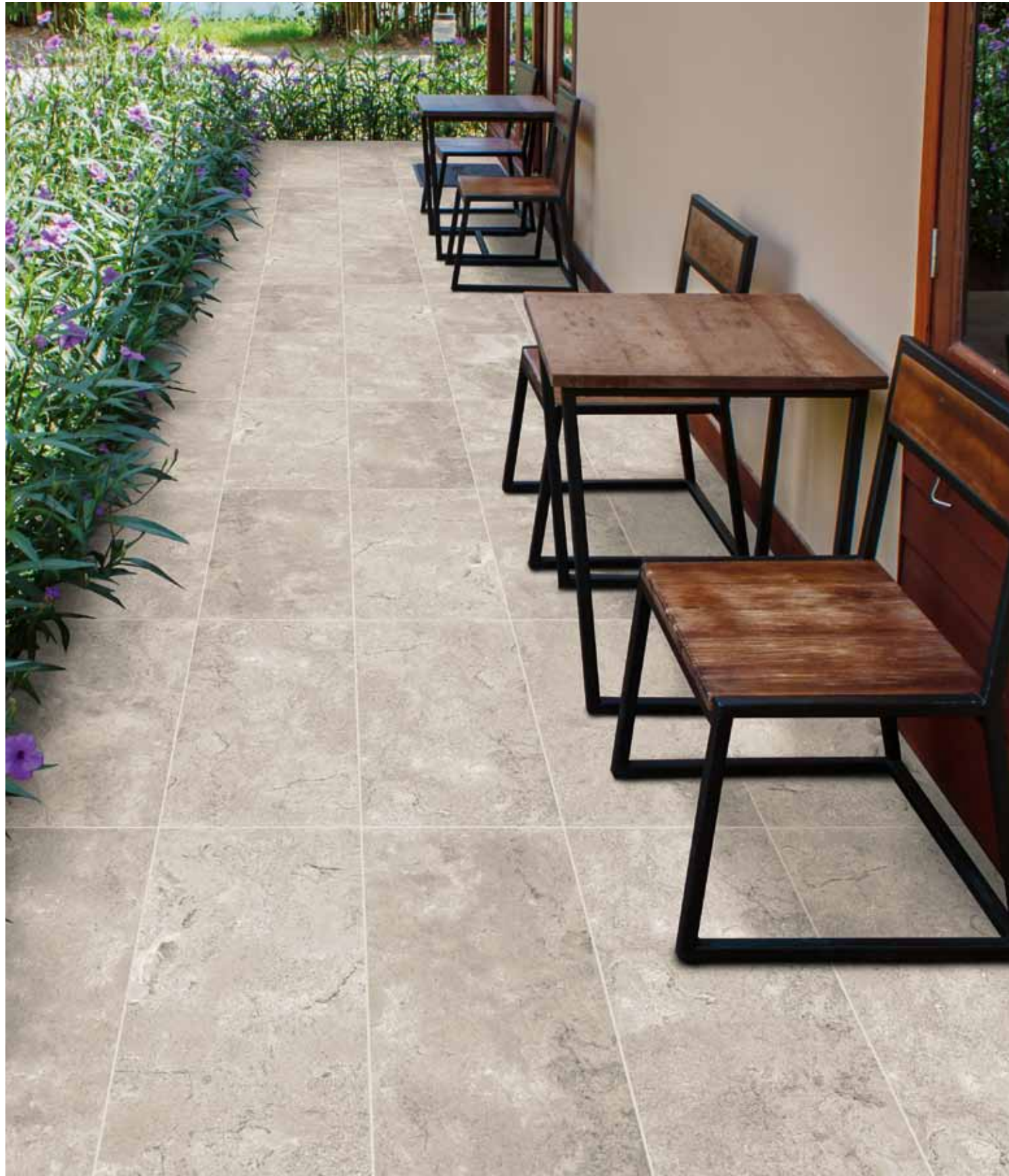

Stone Effect

Travstone 2

24"x24" 16"x32"



S9TS51U
HTS201 Beige
24"x24" . 60x60 cm



SOTS51U
HTS201 Beige
16"x32" . 40x80 cm



S9TS59U
HTS209 Noce
24"x24" . 60x60 cm



S9TS55U
HTS205 Gray
24"x24" . 60x60 cm



SOTS55U
HTS205 Gray
16"x32" . 40x80 cm



S8TS01C
HTS201 Beige Pool Coping
with full round edge
12"x24" . 30x60 cm



SOTS01C
HTS201 Beige Pool Coping
with full round edge
16"x32" . 40x80 cm



S8TS09C
HTS209 Noce Pool Coping
with full round edge
12"x24" . 30x60 cm



S8TS05C
HTS205 Gray Pool Coping
with full round edge
12"x24" . 30x60 cm



SOTS05C
HTS205 Gray Pool Coping
with full round edge
16"x32" . 40x80 cm



T8TS01G33
HTS301 Beige Pool Coping
13"x24" . 33x60 cm
1.18 in - 30 mm thick*



T8TS05G33
HTS305 Gray Pool Coping
13"x24" . 33x60 cm
1.18 in - 30 mm thick*

Coping

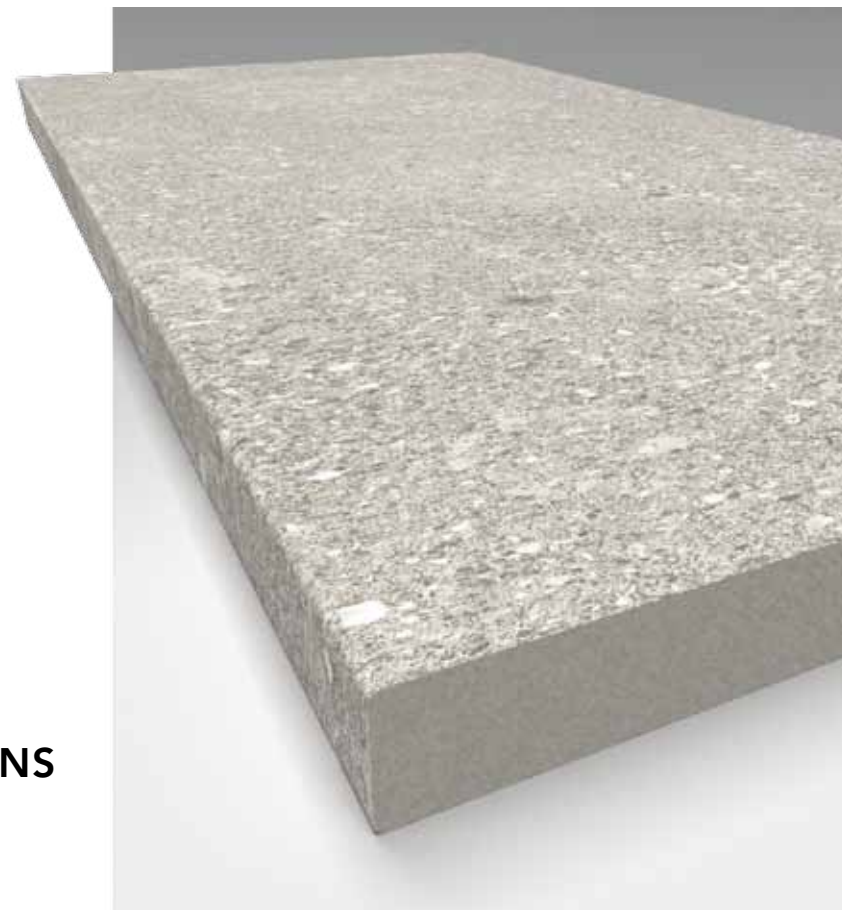

3 CM POOL COPING
MADE IN ITALY

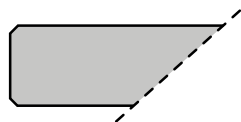

13" x 24" x 3 cm

AVAILABLE ON COLLECTIONS

CHAMONIX 

GOTHAM 

TRAVSTONE  (BEIGE - GRAY)

Cleaning and Maintenance

Thanks to its great hardness and weather-resistance, due2 can be cleaned with almost any detergent. However, we recommend simply using a mild detergent and a water jet. For greater convenience and to avoid formation of limescale deposits, we recommend facilitating drainage with a rubber brush.

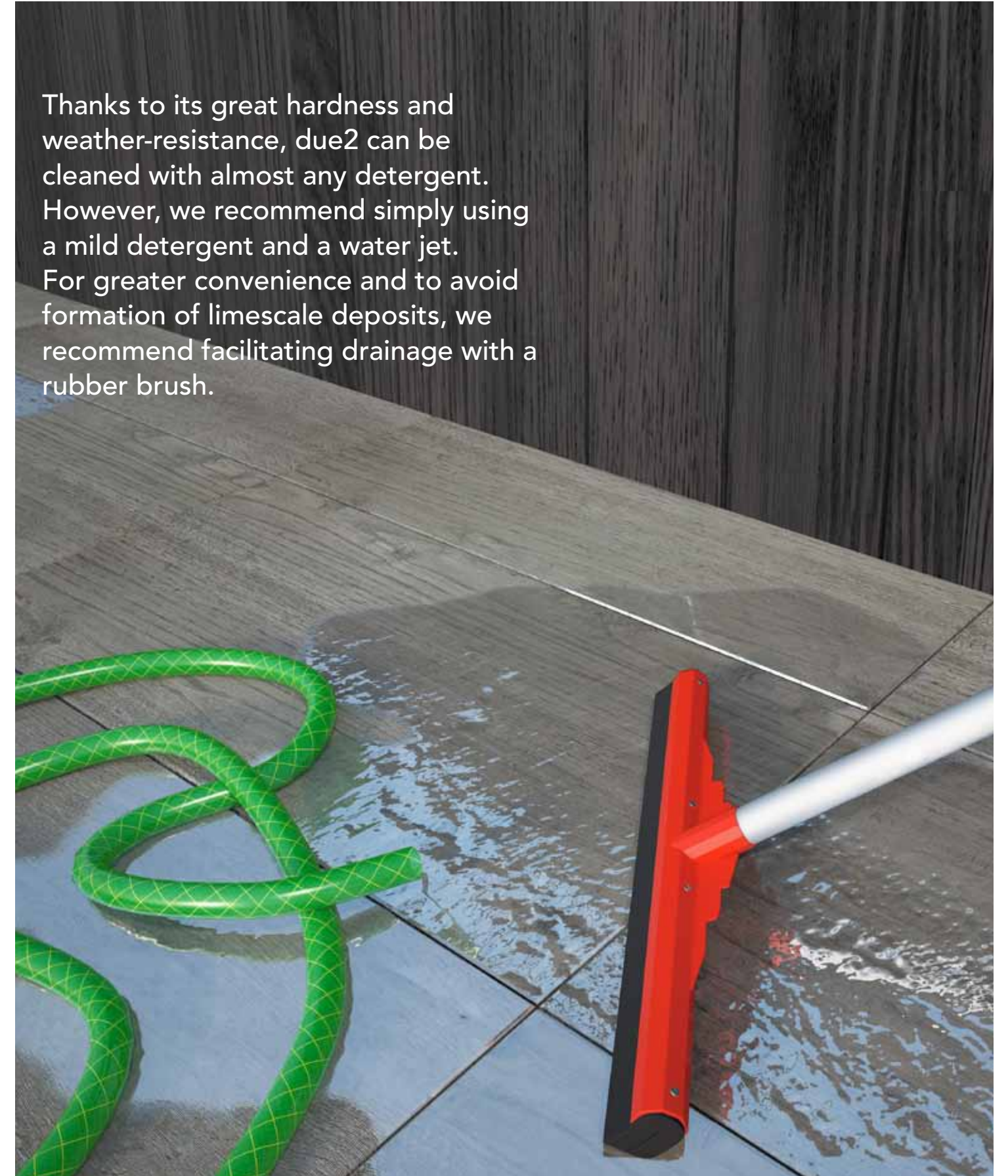

Technical characteristics

TECHNICAL CHARACTERISTICS AND INTERNATIONAL STANDARDS

Our 1st choice tiles are manufactured and selected according to European EN and International ISO regulations. This means that 95% of the contents of first choice must have appearance characteristics corresponding to the standards.

Therefore they must not be perfect (which is impossible for any industrial product) but must have tolerances comprised within the standard limits. These tolerances and those concerning the other physical and chemical characteristics of the product are reported below.

The appearance valuation of the tile must be done examining it (perpendicularly) from 1 meter of distance.

Defects of tiles can be of two types: noticeable (already visible before laying, such as color differences, surface defects, fractures, etc) or hidden (not visible before laying). Complaints about noticeable defects may be made only before tiles are laid, allowing the producer to replace any faulty material. However, if the buyer or tile layer decides to proceed with laying, the responsibility of the producer is invalidated.

Responsibility for hidden defects, if these are notified within the legal time limits, lies the producer.

RECOMMENDATIONS FOR USE

No laboratory test, however efficient it may be, is sufficient to determine the durability of a product. Apart from the obvious factor of the number of foot contacts, durability can also be influenced by the technical characteristics of the product, the place of installation and the possible presence of abrasive agents. We therefore recommend not only that products should be chosen with resistance characteristics that are sufficient for the intended use, as shown in the following chart, but also that wherever necessary, floors should be protected against sand, grit and other abrasives by the use, for example, of mats.

Key to symbols

SHADE VARIATIONS

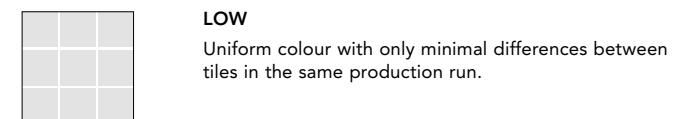

LOW
Uniform colour with only minimal differences between tiles in the same production run.

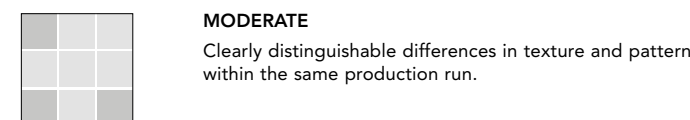

MODERATE
Clearly distinguishable differences in texture and pattern within the same production run.

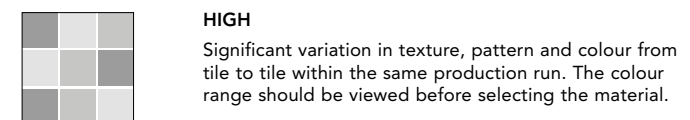

HIGH
Significant variation in texture, pattern and colour from tile to tile within the same production run. The colour range should be viewed before selecting the material.

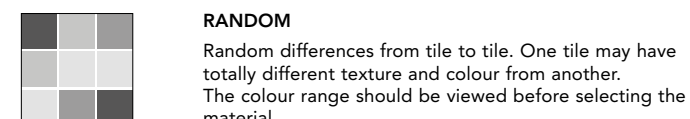

RANDOM
Random differences from tile to tile. One tile may have totally different texture and colour from another. The colour range should be viewed before selecting the material.

RECOMMENDED USE

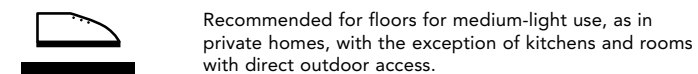

Recommended for floors for medium-light use, as in private homes, with the exception of kitchens and rooms with direct outdoor access.

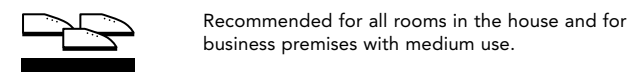

Recommended for all rooms in the house and for business premises with medium use.

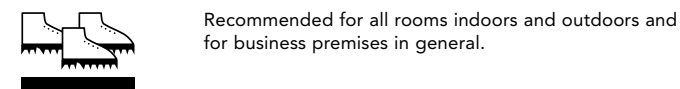











Recommended for all rooms indoors and outdoors and for business premises in general.

ANSI A 137.1: 2019

due 2

Colored Body Porcelain Pavers 20 mm thick

	Established limits	Performances	Norms
 Water absorption	≤ 0,5%	~ 0,1%	ASTM C 373
 Breaking strength (1)	≥ 250 lbf.	~3000 lbf.	ASTM C 648
 Frost resistance	Resistant	Resistant	ASTM C 1026
 Resistance to thermal shock	Resistant	Resistant	ASTM C 484
 Average breaking load for raised floor installation (2)		Classe 1 16"x32" : > 4 kN 24"x24" : > 4 kN Classe 2 16"x48" : > 6 kN	EN 12825*
 Mechanical strength (3)		16"x48" : U3 16"x32" : U4 24"x24" : U7	EN 1339-F*
 Slip resistance (DCOF)	≥ 0,42	≥ 0,60	ANSI A 326.3:2017 release 2019. (DCOF)
 Chemical resistance	As reported	Class: A	ASTM C 650
 Stain resistance	As reported	Class: A	ASTM C 1378
 Recommended use			

* Tests carried out on a different type from that for which the standard is issued

- (1) It states the resistance of a sample piece, leaning on three spots, to a concentrated load placed in the middle.
- (2) It shows the resistance, on raised floor laying as suggested by the catalogue, to a concentrated load applied in the middle.
- (3) It shows the breaking resistance through bending of the product in full size. The load is applied through a horizontal cylinder placed in the middle.

ENVIRONMENTAL PRODUCT DECLARATION (EDP)

See delconcausa.com/download/edpceramictile.pdf to download the EDP report covering Del Conca USA due2 products.

Terms and conditions of sale

1. These Terms and Conditions of Sale shall apply to all orders and contracts entered into by Del Conca USA, Inc. (the "Seller" or "Del Conca") and the Purchaser for the sale of products manufactured or distributed by Del Conca USA (the "Products") unless Seller otherwise specifically agrees in writing. By placing any order for Products, the Purchaser agrees to these Terms and Conditions of Sale. Any other terms or conditions which may at any time be indicated by the Purchaser, in the Purchaser's order form or otherwise (whether oral, typed, written or printed) shall be null and void and of no effect, even if not expressly objected to by the Seller.

2. All prices are stated in U.S. Dollars per square foot or per piece unless otherwise noted.

3. Prices are for first choice material only.

4. Full Truckload (FTL) prices are applied only to orders for shipment of at least 43,000 pounds (including pallet weight) from the Loudon, TN factory and comprised exclusively of materials stored at that specific facility.

5. All pricing is calculated FOB Factory (Loudon, TN), excluding transportation and shipping charges, taxes, fees and custom duties.

6. The Purchaser shall make all payments pursuant to the invoices issued by the Seller, notwithstanding any claim for any alleged defect, fault or irregularity in the Products. Unless otherwise specifically agreed by the Seller in writing, payment by the Purchaser is due upon receipt of Seller's invoice. Invoice for FTL shall be payable within 30 days from the issuance of the invoice. In the event of any delay in payment, the Seller shall have the right to suspend deliveries and may, at its option (i) require immediate payment of all or any part of any and all sums owed by the Purchaser, irrespective of any credit terms previously agreed to, and (ii) terminate the Contract (as well as any and all other contracts with the Purchaser) in whole or in part, and hold the Purchaser liable for damages. In addition, in the event the Seller does not receive full payment by the due date, the Purchaser shall pay to the Seller interest on the unpaid amount, from the due date to the date payment is actually received by the Seller, at the monthly rate of interest of one and one half percent (1 ½%), but not to exceed the highest amount allowed by law. Seller's right to such interest shall be in addition to, and not in lieu of, all other rights and remedies arising by reason of such nonpayment. Any payment received by the Seller may be applied to any outstanding balance owed by the Purchaser to the Seller, as the Seller, in its sole discretion, may determine, any instructions of the Purchaser to the contrary notwithstanding.

7. Del Conca USA reserves the right to apply a surcharge on orders comprising non-full pallets.

8. All orders are subject to availability. No order of the Purchaser will be binding upon Del Conca USA unless accepted by Del Conca USA on Del Conca USA's form of Order Confirmation, signed by an officer or employee of Del Conca USA duly authorized to sign on behalf of Del Conca USA, and then only as and to the extent set forth in such Order Confirmation. Del Conca USA reserves the right to reject any order in whole or in part. Any term, condition or provision set forth in Seller's Order Confirmation which is not objected to by the Purchaser in writing within ten days after the date thereof will conclusively be deemed to have been accepted by the Purchaser. Every order of the Purchaser will be binding on the Purchaser unless and until it is rejected in writing by the Seller, and may not be cancelled, withdrawn or modified by the Purchaser; however, in the event of a partial acceptance by the Seller, the Purchaser will no longer be bound with respect to the parts of the order not accepted by the Seller.

9. Purchaser will take delivery of the Products at the Seller's premises ("ex factory"). Unless otherwise specifically agreed by Seller in writing: (i) all risk of loss or damage to the Products shall pass to the Purchaser upon delivery of the Products by the Seller to a carrier; (ii) the Seller shall not be required to procure insurance to cover the Products during transportation in shipment; (iii) any shipping arrangements made by the Seller with carriers or forwarding agents at the Purchaser's request shall be made solely on the Purchaser's behalf and at the Purchaser's sole cost and risk; (iv) any agent appointed for such shipment shall be solely the Purchaser's agent for all purposes; (v) the Purchaser shall be responsible for all the unloading and receipt of the Products at its destination; and (vi) any claim for loss or damage shall be made by the Purchaser solely against the carrier.

10. Any delivery dates specified by the Seller will be deemed to be estimates only, unless specific commitments are made in writing by the Seller. In no event is the time of delivery of the Products of the essence. The Seller reserves the right to cancel, in whole or in part, or to suspend or delay, in whole or in part, any orders due to (i) shortages of, or failures of Seller's suppliers to deliver, or delays of Seller's suppliers in delivering materials, (ii) work stoppages or other labor troubles, (iii) acts of God or (iv) any event in the nature of force majeure or beyond Seller's control. Delivery dates will be extended by the amount of any additional time required by the Seller to make delivery as a result of any such condition or event. The Seller also reserves the right to discontinue particular Products or lines of Products, or to substitute other Products or lines, in response to production and market requirements and demands. The Purchaser waives any and all claims and rights which the Purchaser might otherwise have arising out of or in connection with or relating to any delay in delivery of the Products for any reason whatsoever or any failure of the Seller to deliver by reason of the exercise by the Seller of any of its rights pursuant to these Terms and Conditions of Sale, including, without limitation, any and all claims for or rights to direct, indirect, incidental, consequential or other damages or compensation, and any and all rights to terminate or cancel the order, in whole or in part.

11. Product representations made in photographs, catalogs, advertisement, sampling and online formats as well as in any other publications are indicative of the product only. Variations in color finish and size can occur and the Seller does not warrant the uniformity of color, tone or shade of the Products or the conformity of the Products to the color, tone or shade of any sample. It is Purchaser's responsibility to verify the suitability of the material before installation.

12. Any Product return shall be previously authorized by Del Conca USA and returned products must be accompanied by an approved Return Authorization form and is subject to a 25% handling charge. Freight for the return is the responsibility of the Purchaser.

13. Limited Warranty / Product Claims: Del Conca USA warrants that its first choice, domestically produced ceramic tile is manufactured according to ANSI A137.1-1988 and meets or exceeds these requirements. If a first choice tile purchased by the Purchaser pursuant to these Terms and Conditions of Sale is proven to contain a manufacturing defect, Del Conca USA will supply, free of charge, material of compatible color and shade, as determined by Del Conca USA. Labor charges are expressly excluded from this warranty. The Purchaser waives any and all other claims and rights which the Purchaser might otherwise have arising out of or in connection with or relating to any breach of warranty or arising out of or in connection with or relating to any defect, fault or irregularity in the Products, including, without limitation, any and all claims for or rights to direct, indirect, incidental, consequential or other compensation or damages, and any and all rights to terminate or cancel the order, in whole or in part.

14. Del Conca USA makes no warranty as to the suitability of its tile for a particular installation. Del Conca USA does not warrant that its glazed or unglazed tile will not scratch, chip, or show signs of wear.

15. Del Conca USA must be notified by the Purchaser of any claims or defects as soon as reasonably possible, but in any case not later than six months after the Products have been delivered by Del Conca USA. Any claim of the Purchaser of any and every kind must be in writing and sent by certified mail, return receipt requested. Failure to make any claim in such manner or within such six month period shall constitute an irrevocable acceptance of the Products.

16. Claims concerning shade, appearance, caliber, finish or obvious defects in first choice production must be communicated before the tile is installed. No claims will be accepted for tile already installed or for defects in other than first choice material.

17. Del Conca USA specifically excludes liability for consequential or incidental damages except where exclusion of consequential damage is not permitted by state law.

18. This limited warranty shall constitute the full extent of Del Conca USA's liability and is in place of all other warranties or representations, express or implied, including, without limitation, any warranty of merchantability or fitness for a particular purpose.

19. Until the Seller collects in full all amounts required to be paid by the Purchaser for the Products, as well as any and all other amounts owed by the Purchaser to the Seller, the Seller retains title to the Products, and shall have a first and senior purchase money security interest in, an lien on, the Products and all proceeds thereof, under the Uniform Commercial Code as in effect in the United States, to secure the payment of all such amounts. By placing an order with the Seller, the Purchaser authorizes the Seller to file any and all financing statements with respect to such security interest which Seller may deem necessary or desirable. The Purchaser shall, at the request of the Seller, execute any and all financing statements and other documents which the Seller may request to perfect or evidence such title and such security interest.

20. In the event the Seller retains a collection agency to collect any amount owed by the Purchaser, or institutes proceedings to collect such amount or to enforce any right against the Purchaser, including enforcement of any security interest granted to the Seller, the Purchaser shall reimburse the Seller for all collection agency fees and costs, or all costs incurred in such legal proceedings, including reasonable attorneys' fees.

21. The Parties agree that the laws of the State of Tennessee (without giving effect to principles of conflicts of law), to the exclusion of the laws of any other state, shall be applicable to all orders or contracts entered into pursuant to this Terms and Conditions of Sale, their construction, interpretation, effect, performance or non-performance or the consequences thereof. For all disputes or controversies which may arise between the Parties out of or in connection with all orders or contracts entered into pursuant to this Terms and Conditions of Sale, their construction, interpretation, effect, performance or non-performance or the consequences thereof, the Parties hereby consent to the jurisdiction of the courts in the State of Tennessee, and agrees that such courts, to the exclusion of all other courts, shall have exclusive jurisdiction with respect to any and all such disputes and controversies.



Tile Council of North America (TCNA)

TCNA is a trade association representing manufacturers of ceramic tile, tile installation materials, tile equipment, raw materials, and other tile-related products.

For further information, please look at the website www.delconcausa.com

The company reserves the right to make any change to products and features shown in this catalogue.
All colors are purely a guide.

Any kind of copy of this catalogue, even partial reproduction, is prohibited.

© 2021 Del Conca USA, Inc. All rights reserved.

APRIL / 2021



Del Conca USA, Inc. - 155 Del Conca Way
Loudon, TN 37774 - USA
Tel 865.657.3550 - Fax 865.657.3554
www.delconcausa.com - sales@delconcausa.com